

Diameter ø68mm Shaft type Incremental Rotary Encoder

■ Features

- Diameter ø68mm, shaft diameter ø15mm
- High speed response frequency : 180kHz
- Connector type
- Suitable for tooling machinery
- Protection structure IP65(IEC standard)
- High shaft loading capabilities(Allowable load weight is 10kgf)

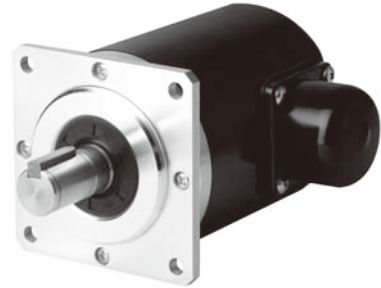

⚠ Please read "Caution for your safety" in operation manual before using.

■ Ordering information

E68S	15	1024	6	L	5
Series	Shaft diameter	Pulse/1Revolution	Output phase	Output	Power supply
Diameter ø68mm, shaft type	ø15mm	500, 600, 1024	6: A, \bar{A} , B, \bar{B} , Z, \bar{Z}	L: Line driver output	5VDC ±5%

■ Specifications

Item	Diameter ø68mm shaft type of incremental rotary encoder	
Resolution(P/R) ^{※1}	500, 600, 1024	
Electrical specification	Output phase	A, \bar{A} , B, \bar{B} , Z, \bar{Z} pahse
	Phase difference of output	Phase difference between A and B : $\frac{T}{4} \pm \frac{T}{8}$ (T=1cycle of A phase)
	Control output	• Low - Load current : Max. 20mA, Residual voltage : Max. 0.5VDC • High - Load current : Max. -20mA, Output voltage : Min. 2.5VDC
	Response time(Rise/Fall)	Max. 0.5μs(Cable : 1m, I sink = 20mA)
	Power supply	5VDC ± 5%(Ripple P-P : Max. 5%)
	Max. Response frequency	180kHz
	Current consumption	Max. 50mA(disconnection of the load)
	Insulation resistance	Min. 100MΩ(at 500VDC megger) (Between all terminals and case)
	Dielectric strength	750VAC 50/60Hz for 1 minute(Between all terminals and case)
	Connection	Connector type(MS3102A20-29P)
Mechanical specification	Starting torque	1.5kgf·cm(Max. 0.15N·m)
	Shaft loading	Radial : 20kgf, Thrust : 10kgf
	Max. allowable revolution ^{※2}	6500rpm
Vibration	1.5mm amplitude or 300m/s ² at frequency of 10 to 55Hz(for 1 min.) in each of X, Y, Z directions for 2 hours	
Shock	Approx. Max. 50G	
Environment	Ambient temperature	-10 to 70°C, storage : -25 to 85°C
	Ambient humidity	35 to 85%RH, storage : 35 to 90%RH
Protection	IP65(IEC standard)	
Unit weight	Approx. 550g	

※1: The number of pulse, output type not indicated in the resolution is available to order.

※2: Make sure that. Max response revolution should be lower than or equal to max. allowable revolution when selecting the resolution.

$$[\text{Max. response revolution}(\text{rpm})] = \frac{\text{Max. response frequency}}{\text{Resolution}} \times 60 \text{ sec}$$

※Environment resistance is rated at no freezing or condensation.

(A)	Photo electric sensor
(B)	Fiber optic sensor
(C)	Door/Area sensor
(D)	Proximity sensor
(E)	Pressure sensor
(F)	Rotary encoder
(G)	Connector/Socket
(H)	Temp. controller
(I)	SSR/ Power controller
(J)	Counter
(K)	Timer
(L)	Panel meter
(M)	Tacho/ Speed/ Pulse meter
(N)	Display unit
(O)	Sensor controller
(P)	Switching mode power supply
(Q)	Stepper motor& Driver&Controller
(R)	Graphic/ Logic panel
(S)	Field network device
(T)	Software
(U)	Other

E68S Series

Control output diagram

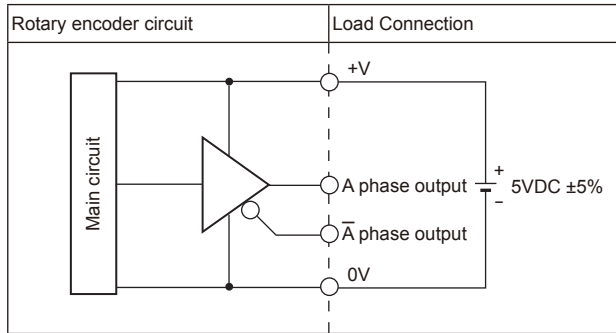

※All output circuits of A, \bar{A} , B, \bar{B} , Z, \bar{Z} phase are the same.

Output waveform

Line Driver output

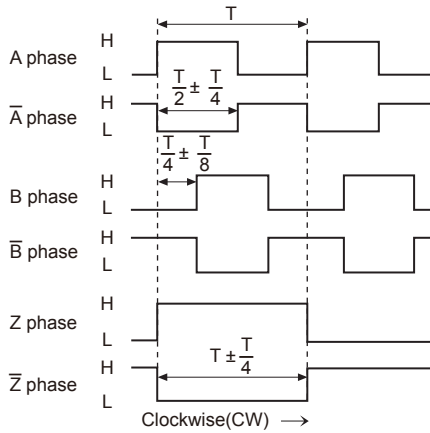

※CW : Right turn as from the shaft

Connections

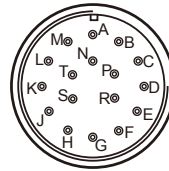

Pin No.	Connection	Pin No.	Connection
A	A phase	K	0V
B	Z phase	L	N-C
C	B phase	M	0V
D	N-C	N	\bar{A} phase
E	5VDC	P	\bar{Z} phase
F	N-C	R	\bar{B} phase
G	N-C	S	N-C
H	5VDC	T	Shield(F.G.)
J	N-C	—	—

※N-C : Not Connected.

※E and H terminals, K and M terminals are connected internally.

Dimensions

(unit: mm)

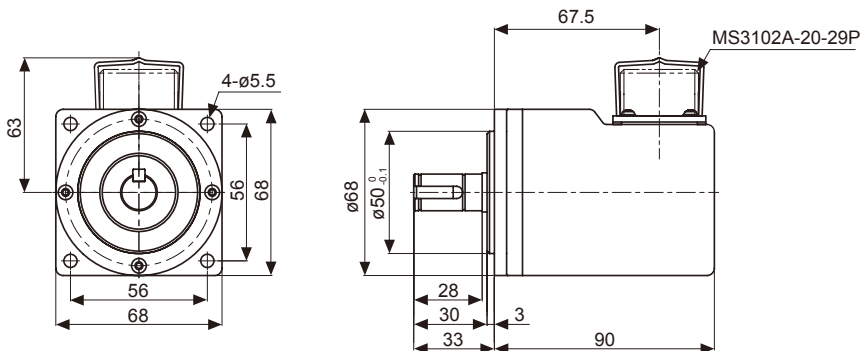

Shaft dimension

